



---

# ZSO

Type: ZSO7300

Z-Wave Socket Outlet

---

Installation Guide and User's Manual





**LOGIC**  
GROUP

Logic Group A/S

Theilgaards Allé 9

DK-4600 Køge

+45 7060 2080

[info@logic-group.com](mailto:info@logic-group.com)

[www.logic-group.com](http://www.logic-group.com)

# Content

1	Safety Instructions .....	4
2	Disposal.....	4
3	Warranty .....	4
4	Product description.....	5
5	Installation guidelines / This chapter is work in progress. ....	6
5.1	Installation.....	6
5.1.1	Cable connecting/disconnecting. ....	6
5.2	Removing the pushbutton cover.....	7
5.3	Removing from frame / insert. ....	7
6	Advanced features.....	8
6.1	Power metering.....	8
6.2	Power off on overload. ....	8
6.3	Set the colors you like. ....	8
6.4	Observe power consumption. ....	8
6.5	LED indication.....	8
6.6	Control of- / from other devices.....	9
7	Behavior within the Z-Wave network. ....	10
7.1	Z-Wave network – add and remove.....	10
7.2	Security. ....	11
7.3	Z-Wave Plus specific information.....	11
7.3.1	Z-Wave specific device information .....	11
7.3.2	Z-Wave specific information. ....	12
7.3.3	Command Class Basic Set command mapping.....	12
8	Factory reset.....	13
9	Association groups. ....	14
9.1	Association groups. ....	14
10	Configuration parameters. ....	15
11	Technical specifications. ....	18

# 1 Safety Instructions

---

 Please read and follow the manual carefully.

Please read this and other device guides carefully. Failure to follow the recommendations set forth by Logic Group A/S may be dangerous or cause a violation of the law. The manufacturer, importer, distributor, and / or reseller will not be held responsible for any loss or damage resulting from not following any instructions in this guide or in other materials.

Keep product away from open flames and extreme heat. Avoid direct sun light or heat exposure.

ZSO7300 is intended for indoor use in dry locations only. Do not use in damp, moist, and / or wet locations.

# 2 Disposal

---



Dispose of the packaging in an environmentally friendly manner. This product is labelled in accordance with European Directive 2012/19/EU concerning used electrical and electronic appliances (Waste Electrical and Electronic Equipment – WEEE). The guideline determines the framework for the return and recycling of used products as applicable throughout the EU.

# 3 Warranty

---

The guarantee conditions for this product are as defined by your representative in the country in which it is sold. Details regarding these conditions can be obtained from the dealer from whom the product was purchased. The bill of sale or receipt must be produced when making any claim under the terms of this guarantee.

## 4 Product description

---

ZSO7300 (from hereon called ZSO) is a smart multifunction socket outlet designed to control electrical appliances via Z-Wave network that can be mounted in a modular wall-box. It is compatible with existing FUGA® frames and wall boxes.

ZSO has RGB indicator LED, that indicates activation of the relay in the socket outlet, and when ZSO is in inclusion or exclusion mode. This indicator can be configured to a desired indication color, or it can indicate current power consumption level when the relay in socket outlet is activated. As well can be used to visualize other events in your Z-Wave network.

ZSO is equipped with the newest 700-series Z-Wave chip which has improved wireless range. This brings great value as the device is also working as a repeater for the Z-Wave network and therefore expands the Z-Wave network coverage.

## 5 Installation guidelines / This chapter is work in progress.

### 5.1 Installation.

ZSO is designed for fitting into standard 1.5-module FUGA wall boxes.

For easy installation ZSO is provided with a connection terminal with push-in terminations. The cable must have a stripped length between 9 and 10 mm. The maximum conductor size is 2.5 mm<sup>2</sup>, or maximum 1.5 mm<sup>2</sup> for stranded conductors with a ferrule.

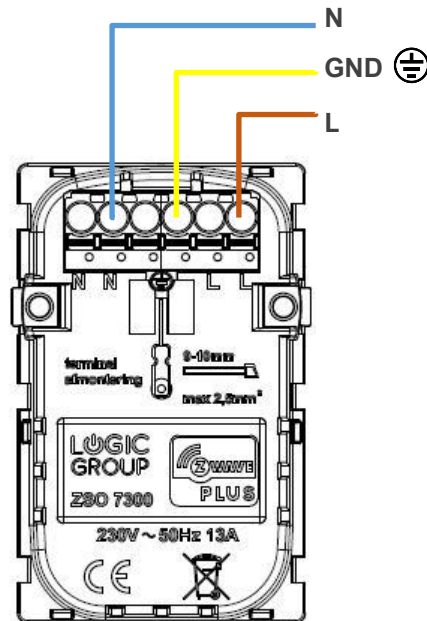

#### 5.1.1 Cable connecting/disconnecting.

When installing a ZSO, simply push solid cables into the connection terminals. Stranded cables must be connected by use of the release-buttons. Activate the release-button on the terminal with a slotted screwdriver with a 2.5 mm slot while pushing in the cable.

When removing the cables, use the release-buttons as described above.

As well it is possible to pull out female connector with slotted screwdriver with a 2.5 mm slot, to do that use the screwdriver to apply force on the female connector while resting it in a position specified (A) on image to the right.

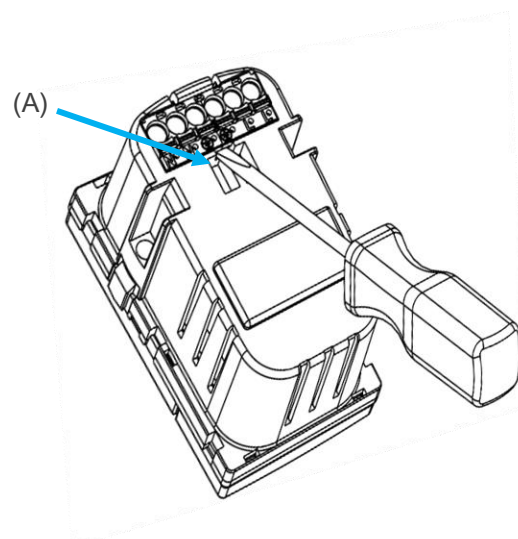

## 5.2 Removing the pushbutton cover.

The pushbutton cover is removed from the device by loosening it with a slotted screwdriver first on one side (A) and then in the same place on the other side (B).



## 5.3 Removing from frame / insert.

Demount the device from a frame by pushing it out at the points (C) and (D) with a slotted screwdriver.

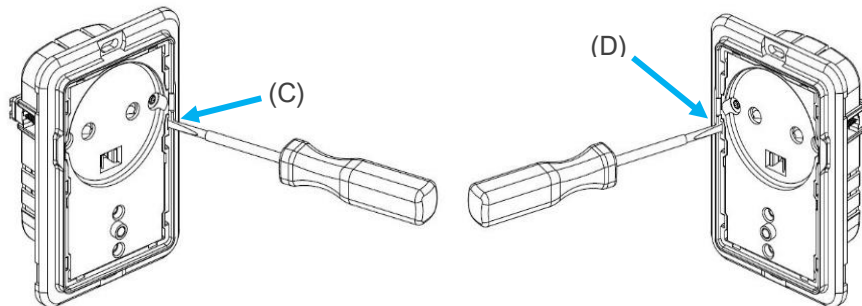

## 6 Advanced features.

---

### 6.1 Power metering.

The time between the reporting can be configured by configuration parameter #2, and by default the reports are sent every minute. The reports are also sent when the consumption of the load changes with more than 50 Watt by default or can be configured by configuration parameter #3, and the sent time **from** the last report is more than 5 seconds.

### 6.2 Power off on overload.

By default, the ZSO will turn the relay off if attached load consumes more than 2900 W to prevent module being damaged. If needed this threshold value can be changed by altering the value of parameter #4 to suit your needs.

### 6.3 Set the colors you like.

By default, the LED indicator is off when relay is OFF, and green when relay is ON.

If desired, parameter #5 can be set to the value of '2' to enable user defined colors for the LED indicator. Parameters #6 and #7 are used set up the desired colors for ON/OFF respectively.

### 6.4 Observe power consumption.

You can always see the log from your Z-Wave network controller, but sometimes you may want to estimate the consumption at the spot without additional actions. ZSO can visualize power approximate power consumption using color coded scheme. Parameter #5 can be set to a value of '1' to enable this behavior.

The LED color displayed will indicate the current power consumption as follows:

- 0 - 15W will be indicated by a **white** LED.
- 16 - 50W will be indicated by a **green** LED.
- 51 - 800W will be indicated by a **yellow** LED.
- 801W and up, will be indicated by a **red** LED.

### 6.5 LED indication.

When the module is not included in a Z-Wave network, the LED will indicate this by a blue light until the module is included in a network.

The brightness of the LED can be controlled by configuration parameter #8. In this parameter the brightness can be set to a level between 0 and 100%, the default brightness is set 10%.

## 6.6 Control of- / from other devices.

When using ZSO with other devices it is preferable to use association groups to control it. See section about Association Groups 1-3.

### Example 1: One ZSO and an external light dimmer.

This example illustrates a system with a ZSO device that controls an external light dimmer with association groups.

In the figure the dimmer is controlled by group 3 (pushbutton) in device #5 by sending **Basic Set** commands to the dimmer device #2.

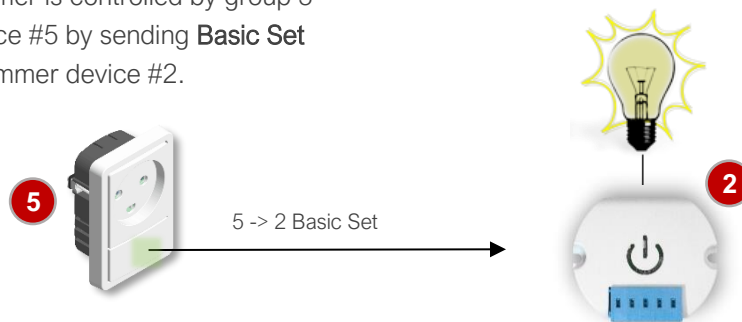

Figure 4: Controlling a light dimmer with pushbutton 2.

### Example 2: MATRIX device controlling ZSO.

To make the same setup as in Figure 5, associate ZSO with MATRIX by adding ZSO node id to association group #6 in device #5:

- *MATRIX device #5:*
  - *Association Group #6 = 9*

If desired, add device 5.2 to association group #2 on the ZSO to keep MATRIX button nr 2 updated with the state of ZSOs relay.

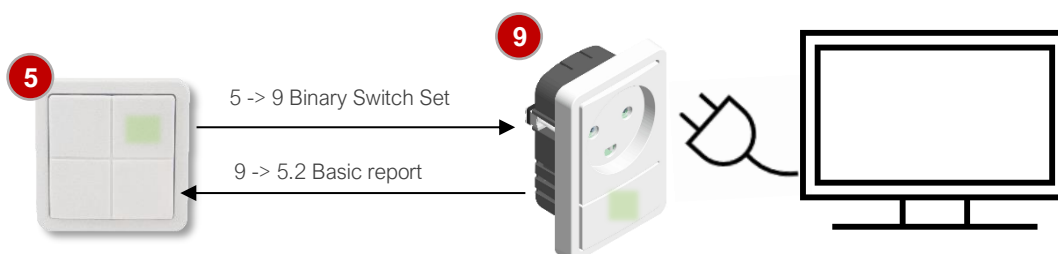

Figure 5: Controlling ZSO from another device.

## 7 Behavior within the Z-Wave network.

This product can be operated in any Z-Wave network with other Z-Wave certified devices from other manufacturers. All non-battery-operated nodes within the network will act as repeaters regardless of vendor to increase reliability of the network.

On delivery, the device does not belong to any Z-Wave network. The device needs to be added to an existing wireless network to communicate with the devices of this network. Devices can also be removed from a network. Both add and remove process are initiated by the primary controller of the Z-Wave network. This controller will be turned into a mode for adding or removing devices. Please refer to your primary controller's manual on how to turn your controller into add or remove mode. Only if the primary controller is in add or remove mode, this device can be added or removed from the network. When the device is removed from the network, it will set the device back to factory default.

If the device already belongs to a network, follow the remove process before adding it in your network. Otherwise, the adding of this device will fail.

### 7.1 Z-Wave network – add and remove.

ZSO7300 is a SmartStart enabled product and can be added into a Z-Wave network by scanning the Z-Wave QR Code present on the product with a controller providing SmartStart inclusion. No further action is required and the SmartStart product will be added automatically within 10 minutes of being switched on in the network vicinity.

Find the QR code and PIN Code under the pushbutton cover (Figure 6a). Find the full DSK on the product packaging or next to QR code.

Add ZSO7300 to a network with Classic Inclusion by pressing once on the switch (I) behind the pushbutton-cover (Figure 6b). The LED will start blinking blue when the adding process is started.

Use same procedure for removing ZSO7300 with Classic Exclusion.

If ZSO7300 already belongs to a Z-Wave network, the remove process must be performed before adding it in a new network. Otherwise, the adding of the device will fail.

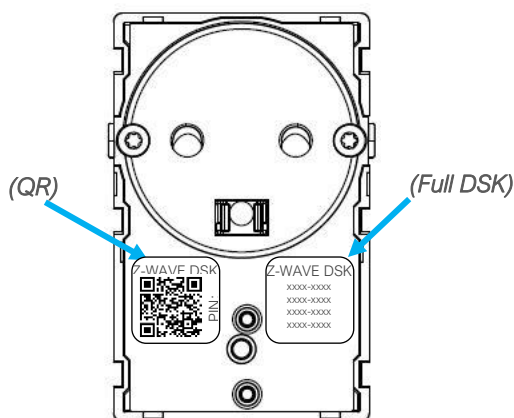

Figure 6a: SmartStart Inclusion

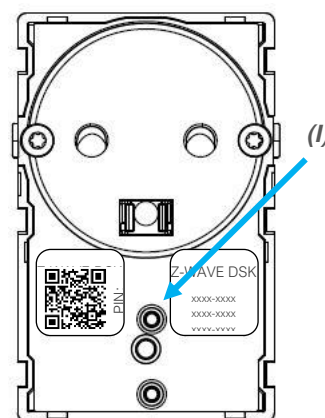

Figure 6b: Classic Inclusion/Exclusion

## 7.2 Security.

ZSO is a Security Enabled Z-Wave Plus product and a Security Enabled Z-Wave Controller must be used to fully utilize the security features of this product.

ZSO can operate in security S0 and S2 mode, this requires that the device be added in security mode during the inclusion process.

ZSO has a QR-code label that can be used when the module is added to the Z-Wave home network. The network controller will ask for a 5-digit code, which can be identified besides the QR-code, and will then ask to confirm the rest of the code that is contained in this QR-code. If needed, the full DSK can be found on the product packaging.

## 7.3 Z-Wave Plus specific information.

ZSO is a Z-Wave Plus device and supports all required command classes for fulfilling the Z-Wave Plus specification. ZSO supports both Security S0 and Security S2.

### 7.3.1 Z-Wave specific device information

ZSO reports following Z-Wave specific device information.

Property	Reported value
Device Type	Binary Switch
Basic Device Class	ROUTING_SLAVE
Generic Device Class	GENERIC_TYPE_SWITCH_BINARY
Specific Device Class	SPECIFIC_TYPE_NOT_USED
Z-Wave Plus Node Type	NODE_TYPE_ZWAVEPLUS_NODE
Z-Wave Plus Role Type	ROLE_TYPE_SLAVE_ALWAYS_ON
Z-Wave Plus Icon Type	ICON_TYPE_GENERIC_ON_OFF_POWER_SWITCH
Z-Wave Plus User Icon Type	ICON_TYPE_GENERIC_ON_OFF_POWER_SWITCH

Manufacturer specific device information:

Property	Reported value
Manufacturer ID	0x0234
Product Type ID	0x0003
Product ID	0x012A

### 7.3.2 Z-Wave specific information.

	Description
<b>Supported Command Classes</b>	Indicator
<b>Controlled Command Classes</b>	Basic

Supported command classes:

Supported Command Classes	Insecure Inclusion	Insecure on Secure Inclusion	Secure on Secure Inclusion
COMMAND_CLASS_ZWAVEPLUS_INFO (V2)	Yes	Yes	
COMMAND_CLASS_TRANSPORT_SERVICE (V2)	Yes	Yes	
COMMAND_CLASS_SECURITY v1	Yes	Yes	
COMMAND_CLASS_SECURITY_2 v 1	Yes	Yes	
COMMAND_CLASS_SUPERVISION (V1)	Yes	Yes	
COMMAND_CLASS_ASSOCIATION (V2)	Yes		Yes
COMMAND_CLASS_ASSOCIATION_GRP_INFO (V3)	Yes		Yes
COMMAND_CLASS_BASIC (V2)	Yes		Yes
COMMAND_CLASS_CONFIGURATION (V4)	Yes		Yes
COMMAND_CLASS_DEVICE_RESET_LOCALLY (V1)	Yes		Yes
COMMAND_CLASS_FIRMWARE_UPDATE_MD (V4) 5 ??????	Yes		Yes
COMMAND_CLASS_MANUFACTURER_SPECIFIC (V2)	Yes		Yes
COMMAND_CLASS_MULTI_CHANNEL (V4)	Yes		Yes
COMMAND_CLASS_MULTI_CHANNEL_ASSOCIATION (V3)	Yes		Yes
COMMAND_CLASS_POWERLEVEL (V1)	Yes		Yes
COMMAND_CLASS_SWITCH_BINARY (V2)	Yes		Yes
COMMAND_CLASS_METER (V5)	Yes		Yes
COMMAND_CLASS_VERSION (V3)	Yes		Yes
COMMAND_CLASS_NOTIFICATION (V8)	Yes		Yes
COMMAND_CLASS_INDICATOR (V3)	Yes		Yes

### 7.3.3 Command Class Basic Set command mapping.

When the ZSO device receives Command Class Basic Set commands, then the command will be mapped as a Command Class Switch Binary Set command.

## 8 Factory reset.

---

*NOTE: Only use this procedure when the primary network controller is missing or is otherwise inoperable.*

ZSO can be factory reset by holding the switch (I) for at least 10 seconds and then release the switch, the LED will then give a short flash.

Refer to chapter 5.3 to remove pushbutton cover properly and avoid damaging your device.

By following this procedure, all configuration parameters and the device network address will be reset back to the values they had when the device was manufactured.

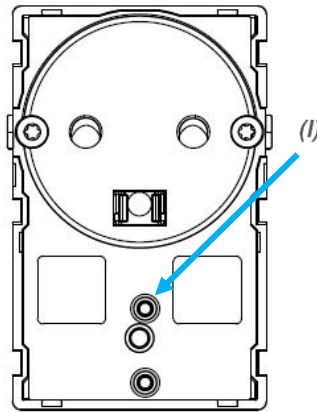

## 9 Association groups.

---

From a Z-Wave controller's point of view, ZSO7300 will consist of a single endpoint-device, i.e., a Power Switch device.

NB. ZSO is a single channel device, not multi-channel.

### 9.1 Association groups.

Below is an overview of the association groups in the ZSO7300 module.

#### Root endpoint

Group 1	<p><i>Lifeline.</i></p> <p>Sends <b>Device Reset</b> notifications, <b>Meter Reports</b>, <b>Indicator Reports</b>, <b>Binary Switch reports</b>, <b>Notification Event Power Management</b></p> <p>Max. nodes in the group: 5</p>
Group 2	<p>Nodes in this group receives <b>Basic Report</b> with the actual state of the binary switch (relay). It can be used by other devices to update their internal states and can be used in multi-way switching configurations for ensuring that all controlling devices has an updated status.</p> <p>Max. nodes in the group: 5</p>
Group 3	<p>Nodes in this group receives a <b>Basic Set</b> command whenever the ZSO button is used to switch the relay ON or OFF. It is the actual state of the relay that is sent in the <b>Basic Set</b> command. This group is <b>NOT</b> used when the relay state is changed by means of Z-Wave commands (as this would result in a kind of self-oscillation and jam the Z-Wave network).</p> <p>So, it will be possible to have two (or more) ZSO's associated with each other by using this group, to have the relay state synchronized when the <u>ZSO buttons</u> are used.</p> <p>Max. nodes in the group: 5</p>

#### \*About Notification CC

If current load is great than value defined in parameter #4, ZSO will shut off its relay and send NOTIFICATION to Z-Wave controller or other nodes in Lifeline Association group.

Command Class:	COMMAND_CLASS_NOTIFICATION
Command:	NOTIFICATION_REPORT
Notification Type:	NOTIFICATION_TYPE_POWER_MANAGEMENT
Event:	NOTIFICATION_EVENT_POWER_MANAGEMENT_OVERLOADED_DETECTED, NOTIFICATION_EVENT_POWER_MANAGEMENT_NO_EVENT

## 10 Configuration parameters.

---

Z-Wave products work out-of-the-box after they are added to the Z-Wave network. However, certain configurations of a device can alter the functionality to better serve the user's needs or unlock further enhanced features.

Parameter 1, Parameter size 1 byte. Startup relay state.

This parameter specifies the state of relay when device is turned on or restarts for some reason (power outage for example).

<i>Value</i>	<i>Description</i>
0	Relay will be set off and load powered off
1	Relay will be set on and load powered on
2	Relay will be set to last state registered before restart

Parameter 2, Parameter size 1 byte. Meter report time.

This parameter specifies how often meter reports are sent via association group 1.

<i>Value</i>	<i>Description</i>
0	Meter reports are never sent.
1 - 127	Report time in seconds. (Default is 60 seconds).
128 - 255	Report time in minutes (minus 127) from 1 – 128 minutes, where 128 is 1 minute.

Parameter 3, Parameter size 2 byte. Watt change threshold

The following value determines how much the Watt consumption should change to initiate an unsolicited report to the controller to be aware of rapid power consumption changes.

<i>Value</i>	<i>Description</i>
1-500	Correspond to Watts (Default is 50 W)

Parameter 4, Parameter size 2 byte. Watt power off threshold

As a safety mechanism it is possible to turn off relay if power consumption gets higher than the defined threshold. This parameter specifies the number of Watts measured which will trigger relay off. If this event occurs device will turn of relay and will start blinking until Button is pushed on the device or Basic Set command is sent to it.

<i>Value</i>	<i>Description</i>
1-3000	Correspond to Watts (Default is 2900 W)

Parameter 5. Parameter size 1 byte. LED mode.

This parameter specifies LED mode.

<i>Value</i>	<i>Description</i>
0	Basic- When off no light in the LED, when on Green LED.  Power consumption: LED indication OFF color is determined by Parameter #6. LED indication colors when ON are mapped to the power consumption:
1	<ul style="list-style-type: none"> <li>- 0 - 15W White.</li> <li>- 16 - 50W Green.</li> <li>- 51 - 800W Yellow.</li> <li>- 801 and up, Red.</li> </ul>
2	User defined colors: When this mode is used, then ON and OFF colors will be determined by the parameters #6 and #7

Parameter 6. Parameter size 4 bytes. LED ON color indication.

This parameter specifies the color levels for the red, green, and blue colors in the RGB LED. This parameter is not used unless configuration parameter #5 is set to the value 2. The default configuration is a green light.

<i>Value</i>	<i>Description</i>
<b>Byte 1: Red color level.</b>	
0 - 255	Specifies the level for the red color. (Default is 0)
<b>Byte 2: Green color level.</b>	
0 – 255	Specifies the level for the green color. (Default is 255)
<b>Byte 3: Blue color level.</b>	
0 - 255	Specifies the level for the blue color. (Default is 0)
<b>Byte 4: Not used.</b>	
0	This byte is not used and must be set to 0.

Parameter 7, Parameter size 4 bytes. LED OFF color indication.

This parameter specifies the color levels for the red, green, and blue colors in the RGB LED. This parameter is not used unless configuration parameter #5 is set to the value 1 or 2. The default configuration is a purple light.

<i>Value</i>	<i>Description</i>
<b>Byte 1: Red color level.</b>	
0 - 255	Specifies the level for the red color. (Default is 143)
<b>Byte 2: Green color level.</b>	
0 - 255	Specifies the level for the green color. (Default is 0)
<b>Byte 3: Blue color level.</b>	
0 - 255	Specifies the level for the blue color. (Default is 255)
<b>Byte 4: Not used.</b>	
0	This byte is not used and must be set to 0.

Parameter 8, Parameter size 1 byte. LED brightness level.

This parameter determines the actual brightness level of the LED in percent.

<i>Value</i>	<i>Description</i>
0 - 100	Percent light brightness in the indicator LED. (Default is 10, which means 10% brightness).

Parameter 9, Parameter size 1 byte. Alter Association Group Security.

This parameter specifies if commands are transmitted as a secure message for each of the association groups. This parameter is only used when the device is included in security mode (either S0 or S2)

<i>Value</i>	<i>Description</i>
0	All messages in all groups are sent as insecure.
1	Messages in association group 2 are sent as secure.
2	Messages in association group 3 are sent as secure.
255	All messages in all groups are sent as secure. (Default)

*NB. The above values are bitmasks and can be added up to select several options.*

## 11 Technical specifications.

---

Dimensions (HxWxD)	71 mm x 46 mm x 33 mm (1½ module)
Connections:	6 poles, 2 x looped Line, 2 x looped Ground, 2 x looped Neutral
Terminals:	Screwless 0.2 – 2.5 mm <sup>2</sup> / 24 – 12 AWG
Power supply:	230 V AC / 50 Hz
Internal Fuse	T2A (fixed)
Max. Attachable Load:	13 A, 13A / 2990 W at 230V DC
Power consumption:	Max. 1 W, Standby 0.6 W
Operating temperature:	10 – 40°C
Humidity:	20 % - 95%, non-condensing
Protection class:	IP20
Radio protocol:	Z-Wave®: EU 868.4MHz – 700 Series.
Approvals:	CE Z-Wave Plus DS/EN 60884-2-D1:2017
Explorer Frame Support:	Yes
SDK:	7.13.6
Device type:	Slave with repeater functionality.
Generic Device Class:	Binary Switch
Specific Device Class:	None
Routing:	Yes
FLiRS:	No
Z-Wave Plus:	Yes
Firmware Version:	1.03
Security:	Security S0, Security S2
Inclusion:	SmartStart Inclusion or Classic Inclusion

